



The ideal combination of warmth and ambiance with an exceptionally large viewing area and built-in custom fireplace look.

**LENNOX**

HEARTH PRODUCTS  
*Innovation never felt so good.™*

DAVE LENNOX  
*signature*  
COLLECTION



*Shoreline™ shown with small four-sided surround*



*Large flames and huge viewing area*



*Hidden side control panel*



*Highly detailed log set*



*Extruded surround for a custom look*

■ With a remarkably large viewing area, a gorgeous built-in look and high-efficiency heat output, the Shoreline™ direct-vent gas fireplace insert provides warm atmosphere for your home. With the largest viewing area in its class, the Shoreline gives you an unparalleled view of the fire. The hand-painted ceramic log set is cast from real wood, giving it a level of detail that is matched only in nature, and a unique tilted burner design allows for natural distribution of the flames for an amazingly realistic burn. To meet your heating needs, the Shoreline is available with either 33,000 or 40,000 BTUs and a convection blower that distributes warmth into your living space. ■

# CUSTOMIZE TO YOUR TASTE

The Shoreline™ is designed to give you the ultimate in creative freedom. With heating options and a variety of design and convenience features, you can customize the Shoreline to reflect your lifestyle and the style of your home. Choose from the following options:

## STEP 1: CHOOSE YOUR BTU LEVEL

The Shoreline is available with two heating options: up to 33,000 BTUs or 40,000 BTUs. To determine which option best suits your needs, match the square footage of your living area with the option listed below.



## STEP 2: CHOOSE YOUR SURROUND

With two available surround sizes, the Shoreline will fit most fireplace openings. Both sizes are also available with three or four sides, depending on your style preference and installation needs.



Large three-sided surround  
28" x 41"



Large four-sided surround  
33-1/2" x 41"



Small three-sided surround  
25-7/8" x 36-5/8"



Small four-sided surround  
29-3/16" x 36-5/8"

## STEP 3: CHOOSE YOUR LINER

The interior liner can change the overall presentation of your fireplace insert. You can choose from three distinctive brick patterns to help create the perfect look and feel.

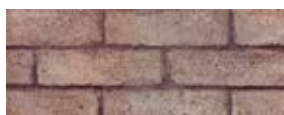

Tan brick



Red brick



Architectural stone

\*Square-foot heating capacities are approximations only. Local conditions, such as elevation, wind, vent configuration and choice of fuel will affect overall appearance of the fire and heating performance. Performance can also vary with home design and insulation, climate, condition and type of fuel used, appliance location, burn rate, accessories chosen, chimney installation and how the appliance is operated.

## STANDARD FEATURES

33,000 or 40,000 BTU output and 155 CFM convection blower to circulate heat

Large viewing area of more than 490 sq. in. for enjoyment anywhere in the room

Unique design with hidden side-mounted controls for a seamless look

Aluminum surround offers a custom built-in fireplace look and makes installation quick and easy

Installs into an average 36" x 16" x 21" factory-built fireplace opening

Angled burner design extends down to the hearth for a true fireplace look and delivers large, natural-looking flames

50% turndown valve allows for adjustable heat and flame height

Limited Lifetime Warranty

## OPTIONAL ACCESSORIES

Remote thermostat

Wall-mounted thermostat

LP conversion kit

Barrier screen

## STEP 4: CHOOSE YOUR THERMOSTAT

Adjust the comfort level of your room with a convenient wall-mounted thermostat or a versatile remote thermostat.



## STEP 5: BARRIER SCREEN

The barrier screen attaches directly to the front of the fireplace insert and helps prevent direct contact with hot glass.



## SPECIFICATIONS

	SHORELINE 33	SHORELINE 40
<b>HEATING CAPACITY*</b>	500 - 1,500 SQ. FT.	900 - 2,000 SQ. FT.
<b>WEIGHT</b>	151 LBS.	151 LBS.
<b>BTU INPUT - NATURAL GAS</b>	HIGH 33,000 LOW 16,500	HIGH 40,000 LOW 20,000
<b>BTU INPUT - LP GAS (PROPANE)</b>	HIGH 33,000 LOW 16,500	HIGH 37,500 LOW 18,750
<b>STEADY-STATE** - NG</b>	83%	83%
<b>STEADY-STATE** - LP</b>	83%	83%
<b>CANADIAN ENERGIDE RATING† - NG</b>	61%	63%
<b>CANADIAN ENERGIDE RATING† - LP</b>	64%	66%
<b>BLOWER</b>	155 CFM	155 CFM
<b>COLINEAR 3" FLEX VENT</b>	SECURITY SECURE VENT™ AND OTHER	SECURITY SECURE VENT AND OTHER

NOTE: The Shoreline™ 33/40 gas insert is shipped as a 40,000 BTU unit and includes a kit that enables field conversion to 33,000 BTU. There is only one insert model number.

\*Square-foot heating capacities are approximations only. Local conditions, such as elevation, wind, vent configuration and choice of fuel will affect overall appearance of the fire and heating performance. Performance can also vary with home design and insulation, climate, condition and type of fuel used, appliance location, burn rate, accessories chosen, chimney installation and how the appliance is operated.

\*\*Steady-state efficiency varies slightly with various pipe configurations.

†Tested to CSA P.4.1-02, "Testing Method for Measuring Annual Fireplace Efficiency."

## DIMENSIONS

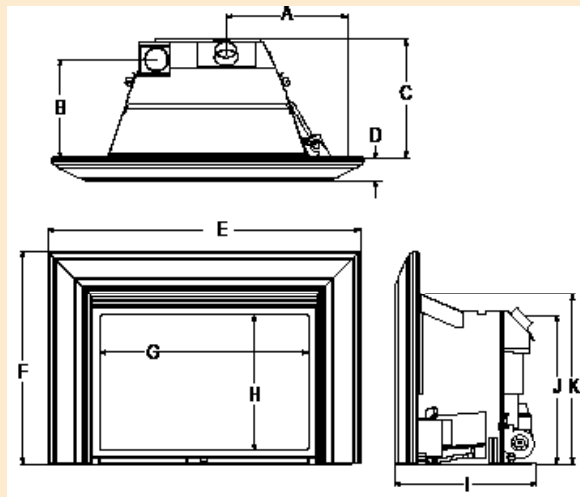

DIMENSIONS		3-SIDED SURROUND	
A	15-7/8"	E SMALL	36-5/8"
B	12-7/8"	LARGE	41"
C	15-3/8"	F SMALL	25-7/8"
D	2-7/8"	LARGE	28"
G	27-3/8"	<b>4-SIDED SURROUND</b>	
H	17-3/4"	E SMALL	36-5/8"
I	18-1/2"	LARGE	41"
J	19-1/2"	F SMALL	29-3/16"
K	22-3/8"	LARGE	33-1/2"

## MINIMUM CLEARANCE TO COMBUSTIBLES

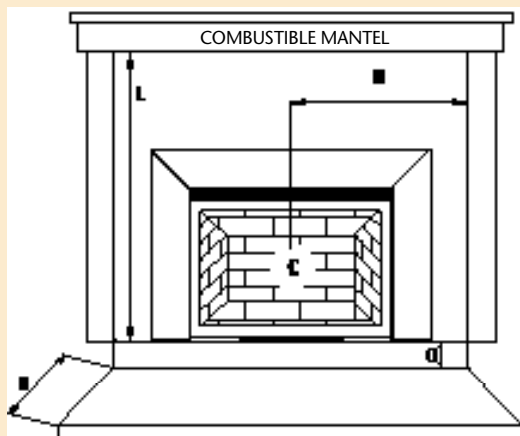

CLEARANCES	MINIMUMS
<b>L</b> BOTTOM OF INSERT TO MANTEL	MINIMUM 35"
<b>M</b> CENTER LINE TO ADJACENT WALL	MINIMUM 30"
HEARTH EXTENSION / HEIGHT‡	<b>N</b> = 12" / <b>O</b> = 0"
HEARTH EXTENSION / HEIGHT‡	<b>N</b> = 0" / <b>O</b> = 8"

‡ Local Codes may require greater hearth protection. Hearth protection must be a minimum of 1" thick non-combustible material or a K factor of 0.84.

## FIREPLACE OPENING

FIREPLACE OPENING	MINIMUMS
FRONT WIDTH	36" MINIMUM
HEIGHT	21-1/2" MINIMUM
REAR WIDTH	19-1/2" MINIMUM
FIREPLACE DEPTH	16" MINIMUM

## PRODUCTS YOU CAN COUNT ON

Lennox is committed to providing you with high-quality products. A qualified dealer can help you find the right product to give you years of comfort and enjoyment.

**HEARTH PRODUCTS**  
Innovation never felt so good.™

© Lennox Industries Inc. 2007

Visit us at [www.lennox.com](http://www.lennox.com), or contact us at 1-800-9-LENNOX.

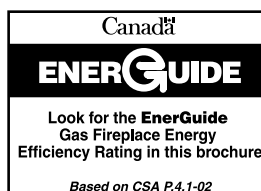

### IMPORTANT NOTES:

As with any heating appliance, fireplace or stove, this appliance is extremely hot during operation. Read and understand all operating instructions before using this appliance. For further information, consult your dealer.

Diagrams, illustrations and photographs are not to scale - consult installation instructions. Product designs, materials, dimensions, specifications, colors and prices are subject to change or discontinuance without notice.

Approved to U.S. and Canadian safety and performance standards - ANSI Z21.88/CSA 2.33-M98 vented gas fireplace heaters.



Tested & Listed By **O-T-L US** Beaverton Oregon USA  
OMNI-Test Laboratories, Inc.